



SB-2501

March 7, 2019

FIREYE®

SB SERIES

FLAME SAFEGUARD CONTROLS



WARNING: Selection of this control for a particular application should be made by a competent professional, licensed by a state or other government. Inappropriate application of this product could result in an unsafe condition hazardous to life and property.

DESCRIPTION

The Fireeye sbSeries Flame Safeguard Control is a compact, microprocessor based, modular burner management system designed to provide automatic ignition and continuous flame monitoring for commercial sizes of heating and process equipment firing any type of fuel.

The sbSeries are tested to EN298.

The control unit includes all the necessary digital logic and analog measuring circuitry to control the sequence and monitor the flame of single gas, oil or combination gas/oil burners. Three available control sequences are no-purge, purge, and modulation (air damper control). The part number specifies the various features such as the flame sensor type, no purge, purge, modulation, proof of air opening at start, and timings; thus the designer has control and protection against field tampering of critical sequences.

LED indicators are available on the front of the unit that provide current operating status of the burner system including lockout alarm. A test jack is recessed into the front cover that provides real time reading of the connected flame sensor. This same test jack is also used to connect to an alpha-numeric display, SB20896. A push button provides reset from lockout condition as well as placing the unit in a check condition usable for pilot turn down test.

The sbSeries flame safeguard control family are of plug-in design and available in models that operate at 120 VAC, 50/60 Hz and 230 VAC, 50/60 Hz making them universally acceptable.

*The wiring base provides a convenient means for connecting field wiring from the burner and valve system to the control unit. There are three styles of bases: an internal terminal base that provides a guarded wiring compartment; an external terminal base for use within a protective control panel; and an expanded external terminal base for use with the modulation sequence control units.

Sensors that may be used with the sbSeries include flame rod (rectified ionization), ultra-violet (UV) scanners, and self-checking UV scanners for continuous operation. Four types of non self-checking UV scanners meet the demands of various environmental conditions.



WARNING: This equipment generates and can radiate radio frequency energy, and if not installed and used in accordance with the instruction manual may cause interference to radio communications. It has been tested and found to comply with the limits for a Class A computing device pursuant to Subpart J of part 15 of FCC Rules, which are designed to provide reasonable protection against such interference when operated in a commercial environment. Operation of this equipment in a residential area is likely to cause interference

SBSeries SPECIFICATIONS

Power Supply:

120VAC (min. 102, max 132) 50/60 Hz.

230 VAC (min 196, max 253) 50/60 Hz.

Power Consumption: 12VA (internal consumption, excludes externally connected loads)

Shipping Weight (Approx): 3 lbs (1.4 kg)



AMBIENT TEMPERATURE LIMITS

	Maximum		Minimum		Weight
SBSeries	140°F	60°C	-40°F	-40°C	3 lbs (1.4kg)
UV Scanner, straight; SB49600-91	257°F	125°C	-4° F	-20° C	1 lb (.45kg)
UV Scanner, 90 degree; SB49600-91	140°F	60°C	-4° F	-20° C	1 lb (.45kg)
UV Scanner, sealed, NEMA4, SB20898	257°F	125°C	-4° F	-20° C	1 lb (.45kg)
UV Scanner, self-check; SB49602-91	140°F	60°C	-4° F	-20° C	7 lbs (3.2kg)
Flame Rod (Tip 2460 F); 69ND1-1000K4, -1000K6, -1000K8	1500°F	616°C	-40°F	-40°C	1 lb (.45kg)
Remote Display, 120 VAC; SB20896	22°F	50°F	32°F	0°C	1 lb (.45kg)

LOAD RATINGS

	Function	Terminal	Inductive Load
	The maximum total connected load cannot exceed 15 Amps.	Gas Valves	3, 5
Ignition		4	375 VA
Motor or Contactor		8	470 VA
Control		A, 10, 11, 12, 13	175 VA



CAUTION: Published load ratings assume that no control be required to handle inrush current more often than once in 15 seconds. The use of control switches, solenoids, relays, etc. which chatter will lead to premature failure. It is important to run through a test operation (with fuel shut off) following the tripping of a circuit breaker, a blown fuse, or any instance of chattering of any external current consuming devices.



WARNING: Selection of programmer and amplifier type for a particular application should be made by a competent professional, such as a Boiler/Burner technician licensed by a state or government agency, engineering personnel of the burner, boiler or furnace manufacturer (OEM) or in the performance of duties based on the information from the OEM.



Flame Safeguard Controls

Eclipse Part Number	Fireye Part Number	Description
VF560222AA	SB560222AA	120VAC,5/10TFI,UV,PURGE
VF560222AB	SB560222AB	120VAC,5/10TFI,UV,PURGE
VF560222XA	SB560222XA	120VAC,5/10TFI,UV,PURGE
VF560222XB	SB560222XB	120VAC,5/10TFI,UV,PURGE
VF560223AA	SB560223AA	120VAC,5/10TFI,FR,PURGE
VF560223AB	SB560223AB	120VAC,5/10TFI,FR,PURGE
VF560223XA	SB560223XA	120VAC,5/10TFI,FR,PURGE
VF560223XB	SB560223XB	120VAC,5/10TFI,FR,PURGE
VF560227AA	SB560227AA	120VAC,5/10TFI,IR,PURGE
VF560227AB	SB560227AB	120VAC,5/10TFI,IR,PURGE
VF560227XA	SB560227XA	120VAC,5/10TFI,IR,PURGE
VF560227XB	SB560227XB	120VAC,5/10TFI,IR,PURGE
VF560232AA	SB560232AA	120VAC,5/10TFI,UV,NO PURGE
VF560232AB	SB560232AB	120VAC,5/10TFI,UV,NO PURGE
VF560232XA	SB560232XA	120VAC,5/10TFI,UV,NO PURGE
VF560232XB	SB560232XB	120VAC,5/10TFI,UV,NO PURGE
VF560233AA	SB560233AA	120VAC,5/10TFI,FR,NO PURGE
VF560233AB	SB560233AB	120VAC,5/10TFI,FR,NO PURGE
VF560233XA	SB560233XA	120VAC,5/10TFI,FR,NO PURGE
VF560233XB	SB560233XB	120VAC,5/10TFI,FR,NO PURGE
VF560237AA	SB560237AA	120VAC,5/10TFI,IR,NO PURGE
VF560237AB	SB560237AB	120VAC,5/10TFI,IR,NO PURGE
VF560237XA	SB560237XA	120VAC,5/10TFI,IR,NO PURGE
VF560237XB	SB560237XB	120VAC,5/10TFI,IR,NO PURGE
VF560242AA	SB560242AA	120VAC,5/10TFI,UV,MODULATION
VF560242AB	SB560242AB	120VAC,5/10TFI,UV,MODULATION
VF560242XA	SB560242XA	120VAC,5/10TFI,UV,MODULATION
VF560242XB	SB560242XB	120VAC,5/10TFI,UV,MODULATION
VF560243AA	SB560243AA	120VAC,5/10TFI,FR,MODULATION
VF560243AB	SB560243AB	120VAC,5/10TFI,FR,MODULATION
VF560243XA	SB560243XA	120VAC,5/10TFI,FR,MODULATION
VF560243XB	SB560243XB	120VAC,5/10TFI,FR,MODULATION
VF560247AA	SB560247AA	120VAC,5/10TFI,IR,MODULATION
VF560247AB	SB560247AB	120VAC,5/10TFI,IR,MODULATION
VF560247XA	SB560247XA	120VAC,5/10TFI,IR,MODULATION
VF560247XB	SB560247XB	120VAC,5/10TFI,IR,MODULATION
VF560322AA	SB560322AA	240VAC,5/10TFI,UV,PURGE
VF560322AB	SB560322AB	240VAC,5/10TFI,UV,PURGE



Flame Safeguard Controls

Eclipse Part Number	Fireeye Part Number	Description
VF560322XA	SB560322XA	240VAC,5/10TFI,UV,PURGE
VF560322XB	SB560322XB	240VAC,5/10TFI,UV,PURGE
VF560323AA	SB560323AA	240VAC,5/10TFI,FR,PURGE
VF560323AB	SB560323AB	240VAC,5/10TFI,FR,PURGE
VF560323XA	SB560323XA	240VAC,5/10TFI,FR,PURGE
VF560323XB	SB560323XB	240VAC,5/10TFI,FR,PURGE
VF560327AA	SB560327AA	240VAC,5/10TFI,IR,PURGE
VF560327AB	SB560327AB	240VAC,5/10TFI,IR,PURGE
VF560327XA	SB560327XA	240VAC,5/10TFI,IR,PURGE
VF560327XB	SB560327XB	240VAC,5/10TFI,IR,PURGE
VF560332AA	SB560332AA	240VAC,5/10TFI,UV,NO PURGE
VF560332AB	SB560332AB	240VAC,5/10TFI,UV,NO PURGE
VF560332XA	SB560332XA	240VAC,5/10TFI,UV,NO PURGE
VF560332XB	SB560332XB	240VAC,5/10TFI,UV,NO PURGE
VF560333AA	SB560333AA	240VAC,5/10TFI,FR,NO PURGE
VF560333AB	SB560333AB	240VAC,5/10TFI,FR,NO PURGE
VF560333XA	SB560333XA	240VAC,5/10TFI,FR,NO PURGE
VF560333XB	SB560333XB	240VAC,5/10TFI,FR,NO PURGE
VF560337AA	SB560337AA	240VAC,5/10TFI,IR,NO PURGE
VF560337AB	SB560337AB	240VAC,5/10TFI,IR,NO PURGE
VF560337XA	SB560337XA	240VAC,5/10TFI,IR,NO PURGE
VF560337XB	SB560337XB	240VAC,5/10TFI,IR,NO PURGE
VF560342AA	SB560342AA	240VAC,5/10TFI,UV,MODULATION
VF560342AB	SB560342AB	240VAC,5/10TFI,UV,MODULATION
VF560342XA	SB560342XA	240VAC,5/10TFI,UV,MODULATION
VF560342XB	SB560342XB	240VAC,5/10TFI,UV,MODULATION
VF560343AA	SB560343AA	240VAC,5/10TFI,FR,MODULATION
VF560343AB	SB560343AB	240VAC,5/10TFI,FR,MODULATION
VF560343XA	SB560343XA	240VAC,5/10TFI,FR,MODULATION
VF560343XB	SB560343XB	240VAC,5/10TFI,FR,MODULATION
VF560347AA	SB560347AA	240VAC,5/10TFI,IR,MODULATION
VF560347AB	SB560347AB	240VAC,5/10TFI,IR,MODULATION
VF560347XA	SB560347XA	240VAC,5/10TFI,IR,MODULATION
VF560347XB	SB560347XB	240VAC,5/10TFI,IR,MODULATION
VF560522AA	SB560522AA	120VAC,10/15TFI,UV,PURGE



Flame Safeguard Controls

Eclipse Part Number	Fireye Part Number	Description
VF560522AB	SB560522AB	120VAC, 10/15TFI, UV, PURGE
VF560522XA	SB560522XA	120VAC, 10/15TFI, UV, PURGE
VF560522XB	SB560522XB	120VAC, 10/15TFI, UV, PURGE
VF560523AA	SB560523AA	120VAC, 10/15TFI, FR, PURGE
VF560523AB	SB560523AB	120VAC, 10/15TFI, FR, PURGE
VF560523XA	SB560523XA	120VAC, 10/15TFI, FR, PURGE
VF560523XB	SB560523XB	120VAC, 10/15TFI, FR, PURGE
VF560527AA	SB560527AA	120VAC, 10/15TFI, IR, PURGE
VF560527AB	SB560527AB	120VAC, 10/15TFI, IR, PURGE
VF560527XA	SB560527XA	120VAC, 10/15TFI, IR, PURGE
VF560527XB	SB560527XB	120VAC, 10/15TFI, IR, PURGE
VF560532AA	SB560532AA	120VAC, 10/15TFI, UV, NO PURGE
VF560532AB	SB560532AB	120VAC, 10/15TFI, UV, NO PURGE
VF560532XA	SB560532XA	120VAC, 10/15TFI, UV, NO PURGE
VF560532XB	SB560532XB	120VAC, 10/15TFI, UV, NO PURGE
VF560533AA	SB560533AA	120VAC, 5/10TFI, FR, NO PURGE
VF560533AB	SB560533AB	120VAC, 10/15TFI, FR, NO PURGE
VF560533XA	SB560533XA	120VAC, 10/15TFI, FR, NO PURGE
VF560533XB	SB560533XB	120VAC, 10/15TFI, FR, NO PURGE
VF560537AA	SB560537AA	120VAC, 10/15TFI, IR, NO PURGE
VF560537AB	SB560537AB	120VAC, 10/15TFI, IR, NO PURGE
VF560537XA	SB560537XA	120VAC, 10/15TFI, IR, NO PURGE
VF560537XB	SB560537XB	120VAC, 10/15TFI, IR, NO PURGE

Flame Scanners and Accssories

Eclipse Part Number	Fireye Part Number	Description
20898	SB20898	NEMA 4 UV SCANNER (ECLIPSE)
49600-90	SB49600-90	90 DEGREE UV SCANNER
49600-91	SB49600-91	STRAIGHT UV SCANNER (ECLIPSE)
49600-98	SB49600-98	MAGNIFYING LENS ASSY (ECLIPSE)
49602-91	SB49602-91	SELF-CHECK SCANNER (ECLIPSE)
49600-98	SB49600-98	MAGNIFYING LENS ASSY (ECLIPSE)
49099	SB49099	COUPLING INSUL, 1/2" FNPT

Wiring Bases		
22194	SB22194	INTERNAL TERMINAL BASE, PL
22195	SB22195	WIRING BASE, PLASTIC, EXPO
49602-40	SB49602-40	MODULATION BASE (ECLIPSE)
Displays		
20896	SB20896	REMOTE DISPLAY, 120V W/KEYPAD
20318	SB20318	CABLE FOR REMOTE DISPLAY

DIMENSIONS

FIGURE 1. SBSeries Control Unit, all models

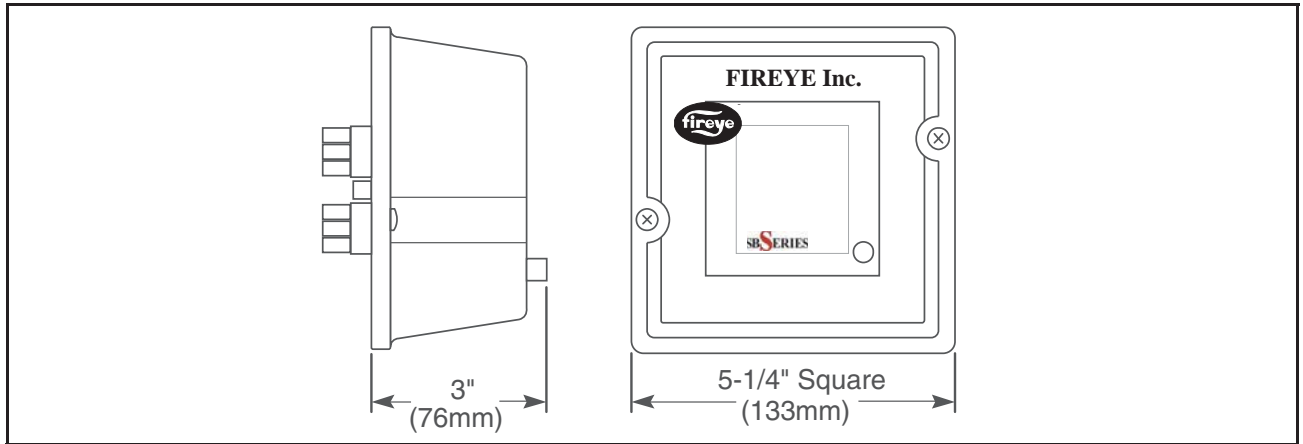

FIGURE 2. SBSeries Bases, NO-PURGE and PURGE sequence models

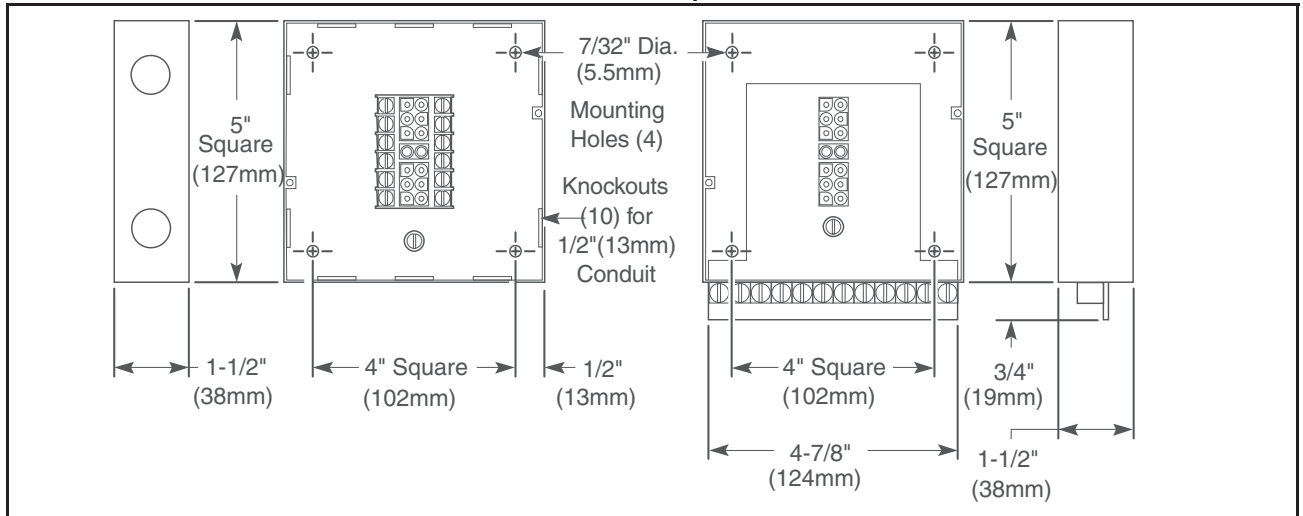

FIGURE 3. sBSeries MODULATION sequence model, SB49602-40

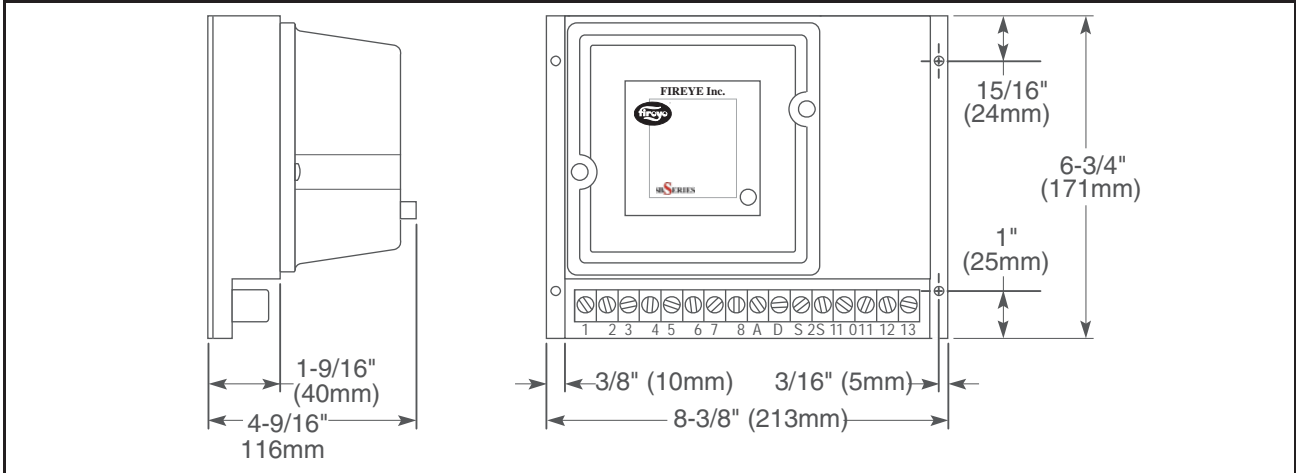
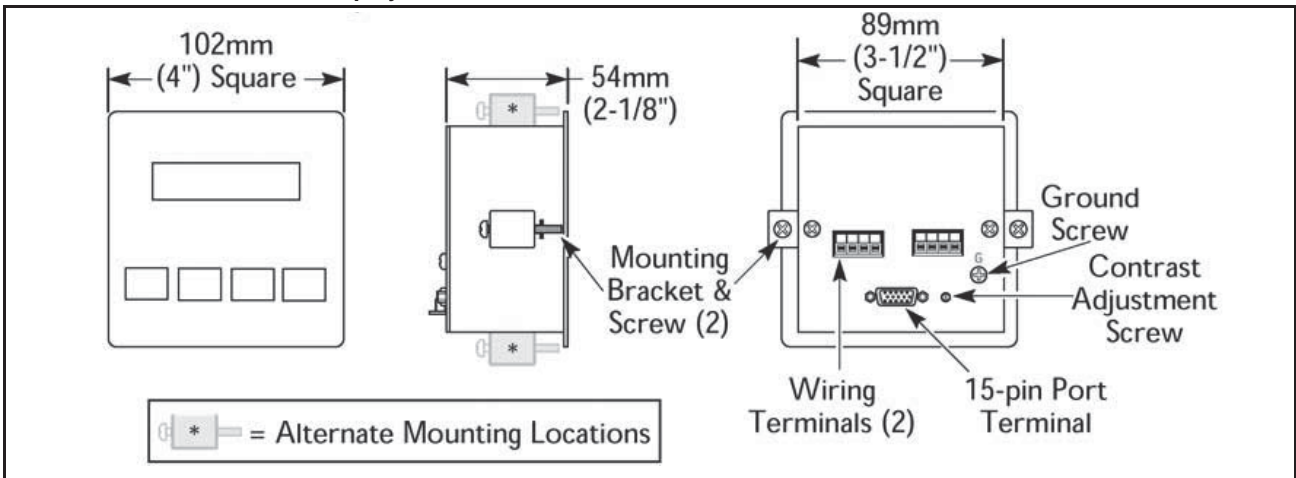
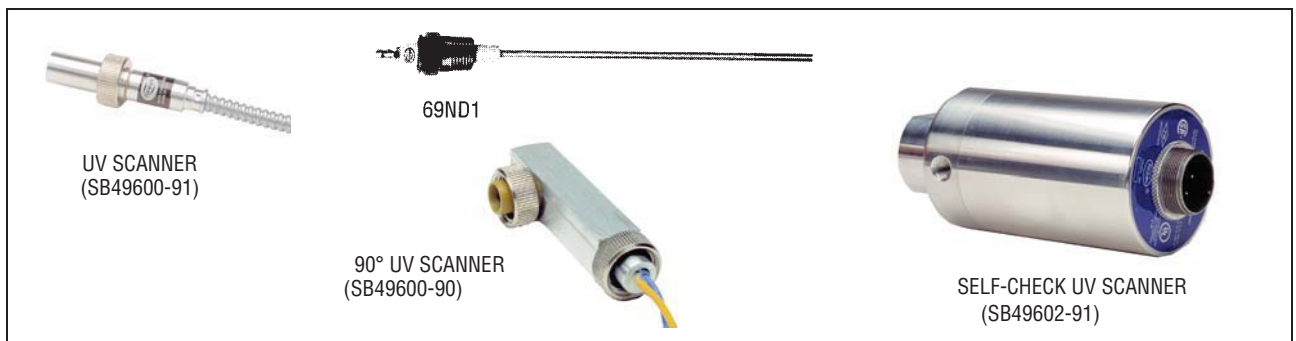

FIGURE 4. Remote Display SB20896



FLAME SCANNERS



CAUTION: The SB49600-91 and SB49600-90 ultra-violet flame scanners and associated amplifier modules are non self-checking UV systems and should be applied only to burners that cycle often (e.g. a minimum of once per 12 hours) in order for the safety checking circuit to be exercised.



WARNING: Installer must be trained and qualified. Follow the burner manufacturers instructions, if supplied. Otherwise, proceed as follows.

INSTALLATION OF CONTROL, SCANNERS AND FLAME DETECTORS

Wiring Base

Mount the wiring base on the burner or on a panel. The location should be free from excessive vibration and within the specified ambient temperature rating. The base may be mounted in any angular position.

All wiring should comply with applicable electrical codes, regulations and local ordinances. Use moisture resistant wire suitable for at least 90°C. Good electrical wiring practice should be followed to ensure an adequate ground system. Refer to Fireye Service Note SN-100 separately and General Grounding Rules later in this document for grounding methods.

A good ground system should be provided to minimize the effects of AC quality problems. A properly designed ground system meeting all the safety requirements will ensure that any AC voltage quality problems, such as spikes, surges and impulses have a low impedance path to ground. A low impedance path to ground is required to ensure that large currents involved with any surge voltages will follow the desired path in preference to alternative paths, where extensive damage may occur to equipment.

Circuit recommendations are found on pages 11 through 13. Consult the factory for assistance with non-standard applications.



WARNING: Controls require safety limits utilizing isolated mechanical contacts. Electronic limit switches may cause erratic operation and should be avoided.



Care must be taken to NOT route the high energy ignition wire in close proximity to the flame sensor wiring.

INSTALLATION GUIDELINES

Terminal 7 - Interlocks and Limit Switch Input

Wire external interlock, control, and limit switches in series to this input. Guard against induced voltage levels to wiring connected to this input. In some extreme wiring runs, reduction of induced voltages may require a load (relay or light) connected to terminal 7 to avoid system error lockouts. This input is the power source for the valve and ignition output terminals. Be sure all switches wired to this input can handle the current required by the total of all loads connected to terminals 3, 4, and 5.

Terminal 6 - Combustion Air Switch Input

For purge and modulation models: Wire any switches and contacts in series to this terminal for proving airflow function and relating to the air failure light. Power must not be immediately present at terminal 6 when power is first applied to terminals 1 or 7. If the combustion air blower is controlled outside of the SBSeries system, then a three-way solenoid valve must be connected between the air switch port and the blower sensing port. The valve de-energized state should vent the switch to ambient.



Terminal 4 - Ignition Wiring

The output terminal normally powers a high voltage transformer. Route the high voltage ignition wiring a sufficient distance from all sensors and other low voltage wiring to avoid electrical interference, which may cause erratic operation of the sbSeries system. Keep the high voltage wire as short as possible. The best condition is to mount the ignition transformer close to the burner and keep a low impedance path from the burner ground to the ground of the transformer. Make sure the high voltage lead and ground return paths do not create a loop antenna around the sbSeries and sensor wiring.

Low Fire Start Switch, (Terminal 3 –resistance through valve coil)

For modulation sequence models: It is possible to wire the system for checking low fire start position prior to pilot ignition. To use this feature, the low fire start switch must be connected between terminal 3 and the pilot valve. On direct spark burners, a by-pass contact must be wired around the low fire switch.

Terminal V or D - Main Valve Closed Switch Input

The system can be wired to check for the main valve closed switch on the main gas valve prior to start-up and after the end of the burner cycle.

For purge and no purge models: The main valve closed switch must be connected to Terminal V and the jumper in the base must be cut.

For modulation models: The main valve closed switch must be wired in series between the airflow switch and the high purge damper switch. To use this feature, the jumper in the base must be cut.

Terminal D - High Purge Switch Input

For modulation models: the system can be wired to check high purge position for the high fire purge portion of the sequence. To use this feature, the red jumper in the base must be cut and the high purge position switch must be connected from terminal D. If this feature is not used, the jumper in the base remains intact a jumper must be installed between terminals 1 and D. (The yellow jumper on the base has no effect whether cut or intact.)

Terminal 1 - Remote Reset

This feature permits remote mounting of a switch to reset the sbSeries. To use this feature, a normally closed remote reset switch must be wired so that power is interrupted to terminal 1. When it is pressed or actuated, the connection to terminal 1 is momentarily interrupted and resets the sbSeries.

Remote Display

The SB20896 remote display is wired according to Figure 10. Mount through a DIN cutout using the two supplied brackets in either the top and bottom or the side slots. Locate the display and wiring to minimize electrical interference. Applying and disconnecting the display power supply should coincide with power to terminal 1 of the sbSeries. Use the appropriate cable (P/N SB20318) to connect to the test jack and to the S2 terminal of the sbSeries wiring base. Do not attempt to parallel the test jack signal to other devices when using a remote display. The LCD display contrast can be adjusted on the back with a small blade screwdriver.

Note:

1. Control circuit wires must meet 90°C (194°F) specification minimum and must be 1.5mm (No. 16 AWG) or larger and in accordance with all applicable codes.
2. Flame sensor wires must be individually run in their own separate conduit; multiple unshielded flame sensor wires CANNOT be run together in a common conduit or wire way (See Sensor Installation Section).
3. The neutral wire to terminal 2 must be at ground potential (bonded at the supply source).

WARNING: Install a modulation sequence model into the modulation style base only; never plug into purge or no-purge bases.

FIGURE 5. WIRING FOR NO PURGE MODELS

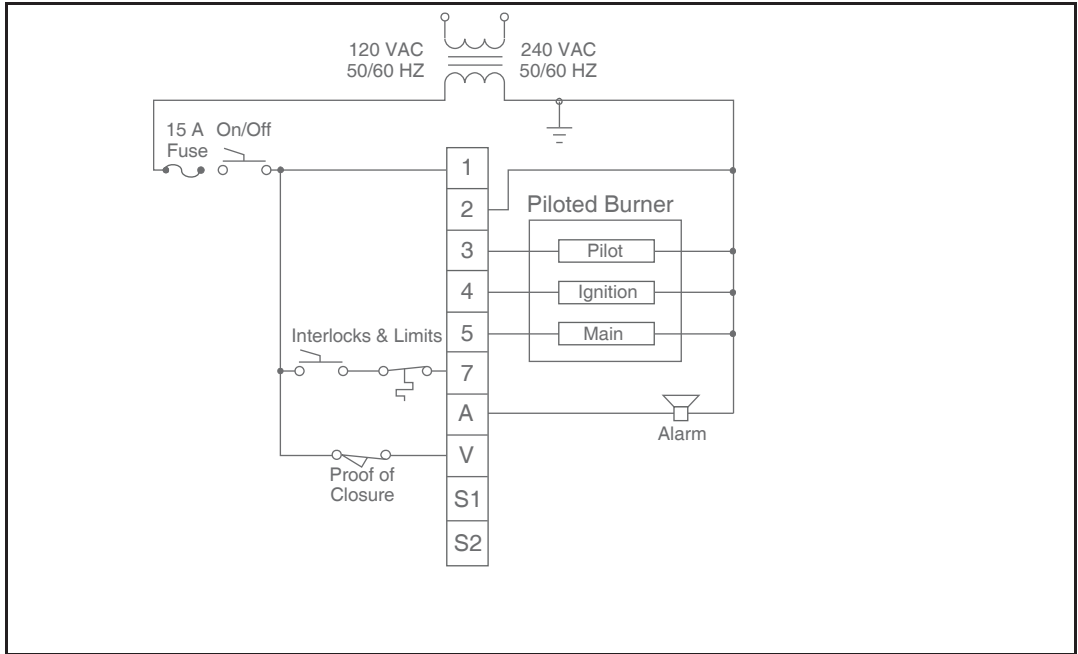

FIGURE 6. WIRING FOR PURGE MODELS

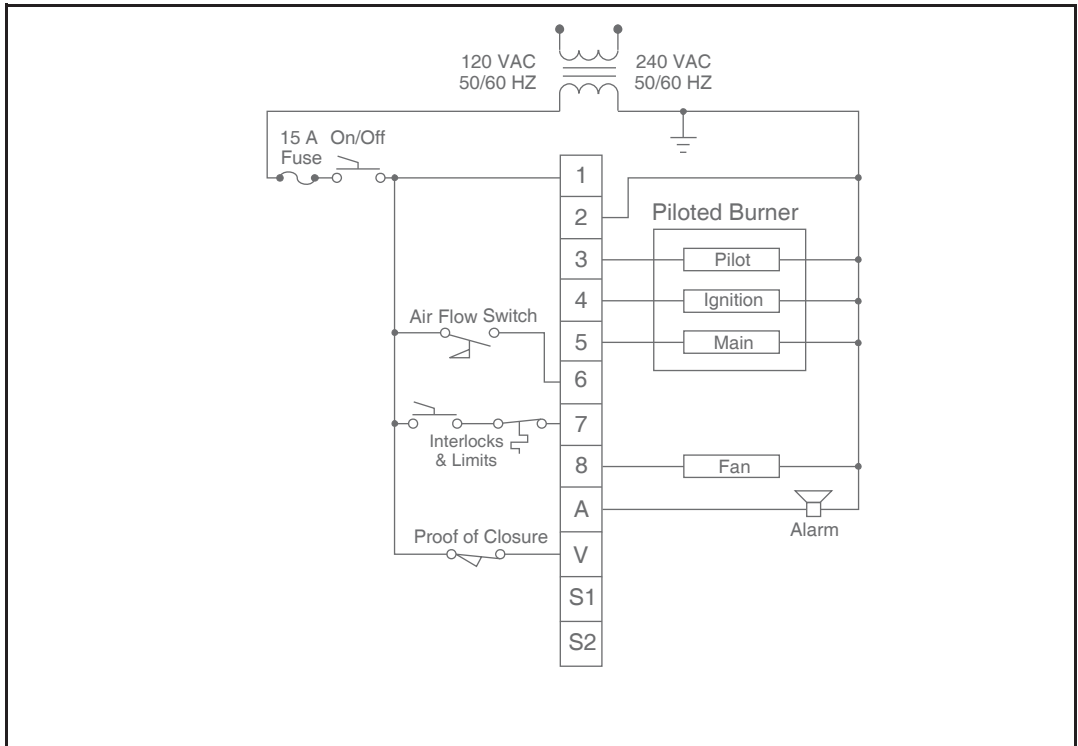

FIGURE 7. WIRING FOR DIRECT SPARK OF MAIN FLAME, NO PURGE MODELS & PURGE MODELS

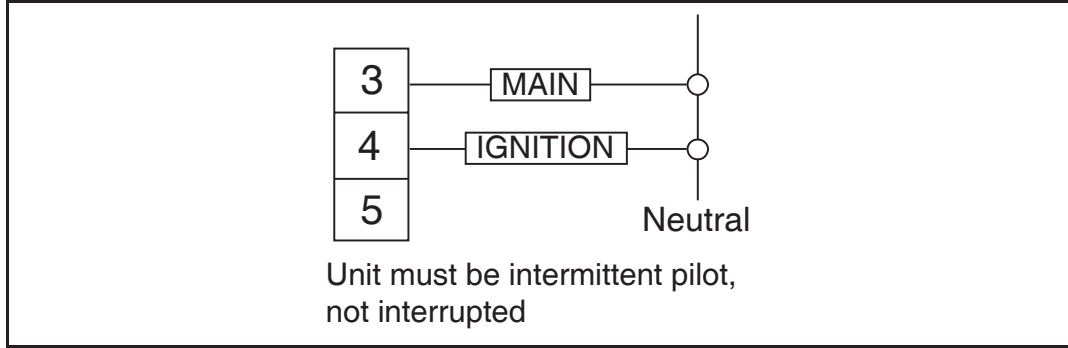

FIGURE 8. WIRING FOR MODULATION MODULES

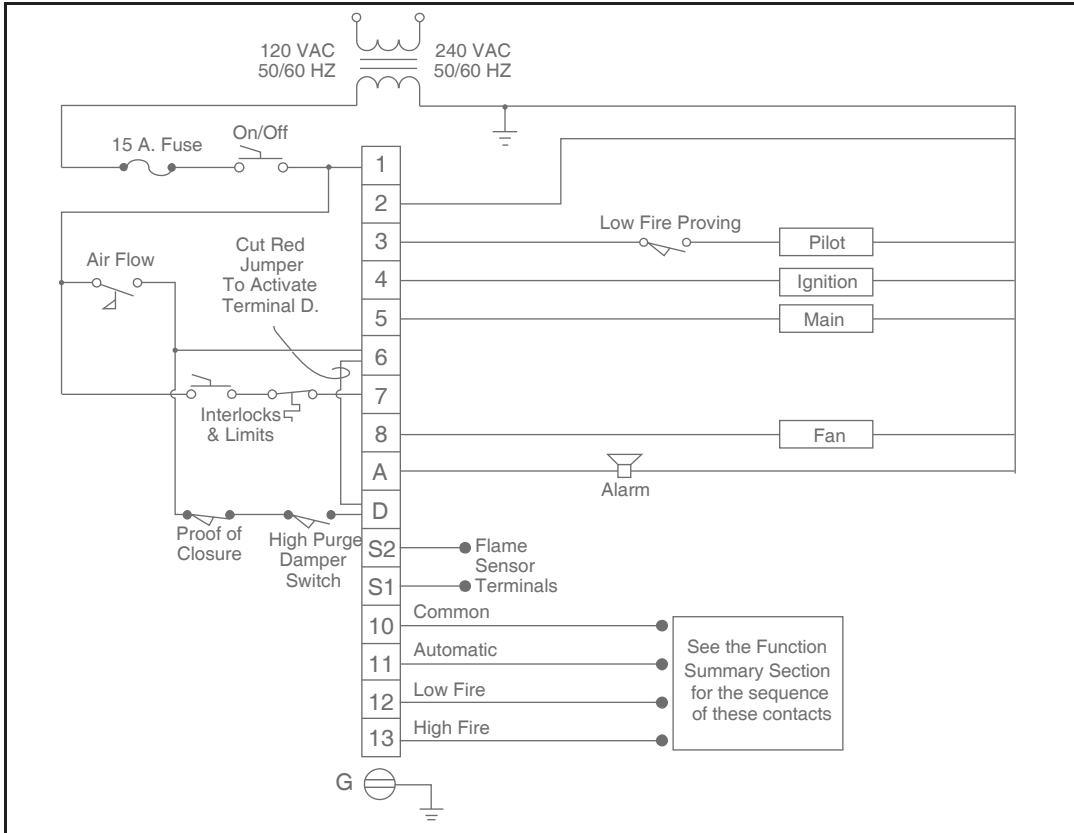

FIGURE 9. WIRING FOR DIRECT SPARK OF MAIN FLAME, MODULATION MODULES

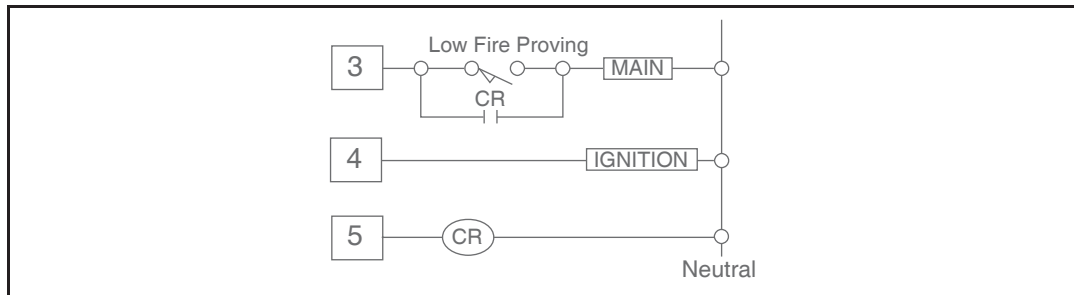

FIGURE 10. WIRING FOR 120 VAC REMOTE DISPLAY MODULE

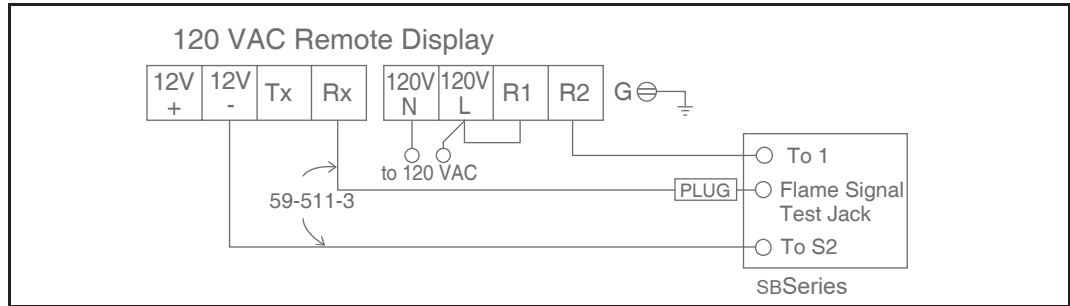
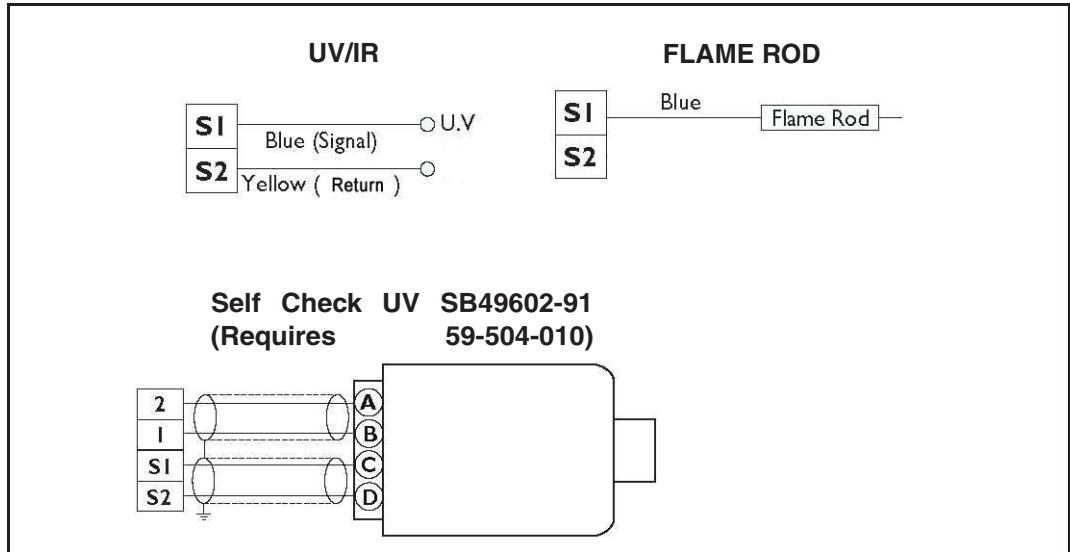

FIGURE 11. TYPICAL CONNECTIONS FOR ALL MODELS



Notes for Figures 5 through 11

1. Ground, shielding & conduit must not be connected to terminal S2.
2. Control circuit wires must meet 90°C (194°F) specification minimum and must be No.16 AWG or larger and in accordance with all applicable codes.
3. Flame sensor wires must be individually run in their own separate conduit; flame sensor wires CANNOT be run together in a common conduit or wireway.
4. Flame signal should read between 4 and 10 VDC with a digital volt meter. Drop off is approximately 4.0 VDC. Positive test jack point is on the cover marked “Flame Signal” with S2.
5. Neutral must be grounded.



OPERATION

Introduction

This section describes the features of the SBSeries CE. It is presented in three categories: Standard Features, Optional Features, System Errors and Lockout Conditions, and the LED Indicator Lights.

Standard Features

The following functions are standard features on the SBSeries models as noted.

Interlocks and Limit Switch Input (Terminal 7)

This input is considered the normal operation control or run input to the SBSeries system. Interlocks are generally pressure or temperature switches that when activated will start the burner. Limit switches are generally pressure, temperature, and other switches that when activated will stop the burner. The interlocks and limit switches are wired in series. A break in this circuit will shut the burner down, but will not produce an alarm or lockout condition.

Combustion Air Switch Input (Terminal 6)

For PURGE and MODULATION sequence models: This input is for monitoring the combustion air switch separately from other interlocks and limits. The SBSeries checks the air flow switch input is open before start-up, closed during operation, and open again at burner shutdown, thus preventing operation with an air switch that is defective, maladjusted or bypassed. This input has about a 2 second delay to filter out and ignore a momentary interruption.

If the input is improperly powered before the fan output is energized, the system error light will blink. The input must de-energize within 30 seconds or the SBSeries will alarm and lockout.

After the fan output has energized, the air switch input must be made within 10 seconds. If not proven, then the system will lockout and the alarm output and the air failure light will come on. However, if the unit has the air switch input hold feature, the sequence is held indefinitely without causing a lockout. Then when the air switch input is made, the sequence continues.

If the air switch opens during the main firing cycle, the system will lockout and the alarm output and the air failure light will come on. However, if the unit has the recycle option and the main output has been operating for at least 35 seconds, the SBSeries will shut-down and restart.

Pre-Purge

For PURGE sequence models: The SBSeries delays the sequence after the air switch is proven by the specified purge time. Once completed, the sequence continues to the trial for ignition.

For MODULATION sequence models: The purge time is doubled into two sequences. The first is a high fire purge for the specified time. The second is a low fire purge allowing the air butterfly valve time to achieve starting position. The high and low fire purge times are the same as determined by dipswitches SW 4 - SW 7.

The modulation terminals will sequence as follows:

SEQUENCE STEP	INTERNAL CONTACTS	FUNCTION
Power Off	Terminals 10 to 12	LOW
Power On, Limits Off	Terminals 10 to 12	LOW
Purge to High Fire	Terminals 10 to 13	HIGH
Purge to Low Fire	Terminals 10 to 12	LOW
Automatic Modulation	Terminals 10 to 11	AUTO
Alarm and Lockout	Terminals 10 to 12	LOW

DIP SWITCH SELECTION

Introduction

This section details the location, selection and description of the sbSeries DIP switches which allow for sequence and timing functions as well as system configuration.

DIP Switch Location

All of the DIP switches are located in the back of each sbSeries unit. (see following pictures).

DIP Switch Access

To gain access to the DIP switches, the sbSeries must be separated from the back box. This separation will expose the DIP switches on the back of the sbSeries unit.

No Purge DIP Switch Settings

No Purge models of the sbSeries only use three of the eight DIP switches as shown in the following pictures. They are as follows:

SW1: Recycling mode selection (On=Recycling; Off=Non-Recycling)

SW2: Pilot selection (On=Intermittent, where pilot remains on during burner cycle; Off=Interrupted, where pilot valve closes after the main burner is established)

SW3: Trial for ignition range selection (For SB5602/SB5603units: On=10 seconds; Off=5 seconds. For SB5605 units: On=10 seconds; Off=15 seconds).

Modulation and Purge DIP Switch Settings

SW1: Recycling mode selection (On=Recycling; Off=Non-Recycling)

SW2: Pilot selection (On=Intermittent, where pilot remains on during burner cycle; Off=Interrupted, where pilot valve closes after the main burner is established)

SW3: Trial for ignition range selection (For SB5602/SB5603units:On=10 seconds; Off=5 seconds. For SB5605 units: On=10 seconds; Off=15 seconds).

SW4: through SW7: Purge time selection. Total purge time is the sum of each switch selected. If all are set off, the trial for ignition starts when the air switch input comes on. Switch timings are:

SW4 = 15 sec, SW5 = 30 sec, SW6 = 60 sec, SW7 = 120 sec.

SW8: Post purge selection. (On=15 seconds post purge)

If the air switch opens during the main firing cycle, the system will lockout and the alarm output and the air failure light will come on. However, if the unit has the recycle option and the main output has been operating for at least 35 seconds, the sbSeries will shut-down and restart.

NOTE: Flame Failure Response = 3 seconds +/- 0.5 seconds for all models.

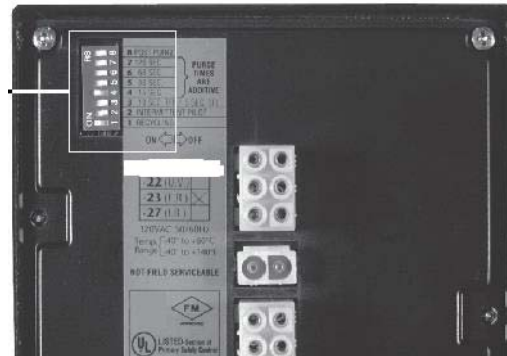
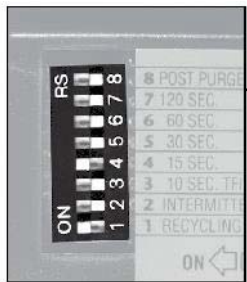

Main Fuel Valve Closed Switch (Terminal V)

For NO-PURGE and PURGE sequence models: The sBSeries can be interlocked with the main valve closed position switch. This feature checks the switch position before start-up and after shut-down to insure proper valve operation when the jumper on the base is cut.

For MODULATION models: When wired, the system checks for the low fire start position prior to light off.

Main Fuel Valve Closed / High Fire Purge Check (Terminal D)

For MODULATION sequence models: This feature is enabled when the jumper on the base is cut. The system checks that the high fire purge position switch and the main valve closed switch are both made at the end of the high fire purge.

Low Fire Start (Terminal 3 – impedance)

For MODULATION sequence models: When wired, the system checks for the low fire start position prior to light-off.

Pilot Test Mode

In the pilot test mode, the sBSeries will hold the sequence once the pilot flame is established and prevents energizing the main valve (terminal 5).

Depressing the TEST/RESET button on the front cover enters this mode. When in the pilot test mode, the green “INTERLOCKS CLOSED” light blinks. To exit the pilot test mode, simply push the TEST/RESET button 3 times. The green "INTERLOCK CLOSED" light stops blinking, but remains lit.

Interrupted or Intermittent Pilot

An interrupted pilot shuts off at the time specified by the part number after the main valve is energized. An intermittent pilot (specified as 00 time) continues during the entire main flame firing cycle.

Spark, Pilot Flame & Main Flame Separation

During the trial for ignition period (TFI), the pilot and ignition outputs remain energized. At the end of the TFI, the pilot output remains on and the ignition output is de-energized. After a five second delay to prove the pilot or start flame, the main gas valve is energized.

Post Purge

For PURGE and MODULATION sequence models: Post purge maintains the combustion air fan output for the time specified after the interlocks and limit switch input have opened.



OPTIONAL FEATURES

The following functions are optional features that must be specified when ordering.

Recycle Mode

With “R” specified, the sBSeries will restart the sequence after flame or air failure. The recycle mode allows the system to re-initiate the start-up sequence automatically only if the main burner has been operating for at least 35 seconds. If the pilot or start flame fails to light during recycling, the system will alarm and lockout. If the recycle is successful and the main burner is once again operational for at least 35 seconds, the system is enabled for another recycle. At no time will the system recycle in the event of a pilot or starting flame failure.

Air Switch Input Hold

For PURGE and MODULATION sequence models: With “H” specified, the sBSeries holds the sequence indefinitely until the air switch input is made. Once made, normal functional sequence continues.



Manual Reset on Power Outage

With “B” specified, the TEST/RESET button must be pressed twice (in and out) to start the sequence. The system error light blinks rapidly (about 4 times per second) and a remote display will show “PUSH RESET TO START”.

Remote Display

A remote display is available for the sbSeries. The model SB510 operates on 120VAC and has a keypad for reset function. The display is mounted through the panel-door and features a liquid crystal display in a DIN housing. The unit connects to the sbSeries by a cable to the flame signal test jack, and receives a serial communication on each sequence state change.

The display incorporates the following functions:

1. Provides status messages for the sbSeries sequence, see “Remote Display Messages”.
2. Indicates lockout conditions when they occur, as well as the amount of time into the sequence when the lockout occurred.
3. Provides continuous monitoring of the burner’s flame signal strength and run time during main burner operation.

System Errors and Lockout Conditions

FAULT CONDITION	LOCKOUT CONDITION
(Illuminated by the red “Fault Condition” LED on the front cover) prevents gas ignition. The unit will continue its sequence after the error is cleared	Energizes the alarm output and deenergizes the gas valve and ignition outputs. The unit must be reset to clear the alarm and start the sequence. To reset, the button must be pressed twice so that the button is in the out position

The following fault conditions result in immediate lockout conditions:

1. Wiring error that puts external voltage on the output terminals.
2. Welded internal contacts or other malfunctions in the sbSeries.
3. Main fuel valve closed position switch is open after cycle shutdown or before start-up. The system error light blinks twice and then remains on. The fan output terminal 8 will energize.
4. Low fire fail (for modulation model) – the low fire switch is open prior to trial for ignition.
5. High fire fail (for modulating model) – the high fire switch is not closed at the end of high fire purge.
The following situations will result in a lockout condition:
6. Air failure (for purge and modulation models) – loss of combustion air anytime during the operational cycle. The Air Failure LED will be on for this condition. (See “Recycle Mode”).
7. Pilot flame fail – loss of flame during the trial for pilot ignition period. The Flame Failure LED will be on for this condition.
8. Main flame fail – loss of flame during the main burner trial for ignition or run period (recycling not selected). The Flame Failure LED will be on for this condition. The following result in lockout conditions after 30 seconds, the system error light blinks about 14 times and then remains on:
9. If a flame is detected out of sequence, which may be caused by:
 - a. a faulty scanner;
 - b. electrical interference on the sensor wiring;
 - c. a flame exists in the burner or in the line of sight of a scanner, due to a gas leak, product fire or other condition.
10. Air flow switch closed before start-up (for purge and modulation models).



Status Lights and Push-Button

All of the status lights and the TEST/RESET push-button are located on the front cover of the SBSeries. This section describes their respective functions.

Interlocks Closed

This green LED illuminates when the operation limits are made.

The limits are wired in series to terminal 7. This input becomes energized to begin the burner sequence. When in the test mode, this LED blinks (see “Pilot Test Mode”).

Air Failure

For purge and modulation models: this red LED illuminates whenever combustion air is lost during the operational cycle of the SBSeries.

Fault Condition

This red LED illuminates when a system error is detected (see “System Errors & Lockout Conditions”).

Flame Failure

This red LED illuminates when a pilot or main flame fails.

Low Fire

For modulation models: this yellow LED illuminates during the low fire period of the purge cycle.

High Fire

For modulation models: this red LED illuminates during the high fire period of the purge cycle.

Auto

For modulation models: this green LED illuminates during the automatic period which occurs 20 seconds after the main valve is energized.

Test/Reset

This push-button is used to activate the pilot test mode or to reset the SBSeries unit.

Flame Signal

This red LED is located behind the signal test port and illuminates when a flame signal is present.

Note: Communication signals from the remote display are superimposed on the flame signal test jack. During a valid flame On condition these communication signals will appear to be negligible in comparison to the flame signal (if measuring the flame signal with a DVM for example). When flame is off, the display communication signals or display “discover” signals will appear prevalent on the flame signal test jack. Use of an analog DVM will mask this phenomenon to an extent.

TYPICAL SEQUENCE FOR NO-PURGE MODELS

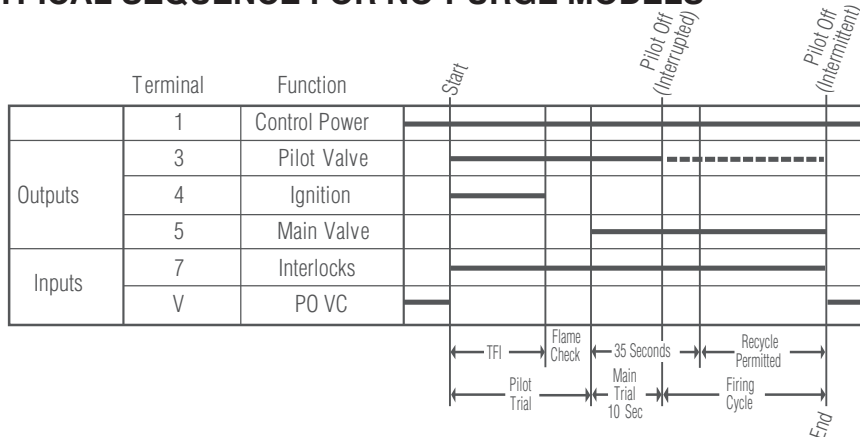

TYPICAL SEQUENCE FOR PURGE MODELS

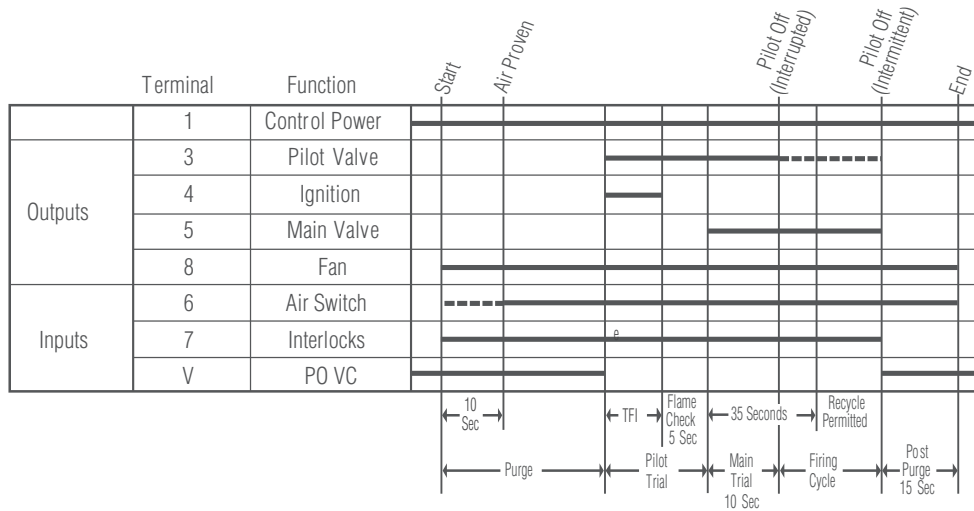

TYPICAL SEQUENCE FOR MODULATION MODELS

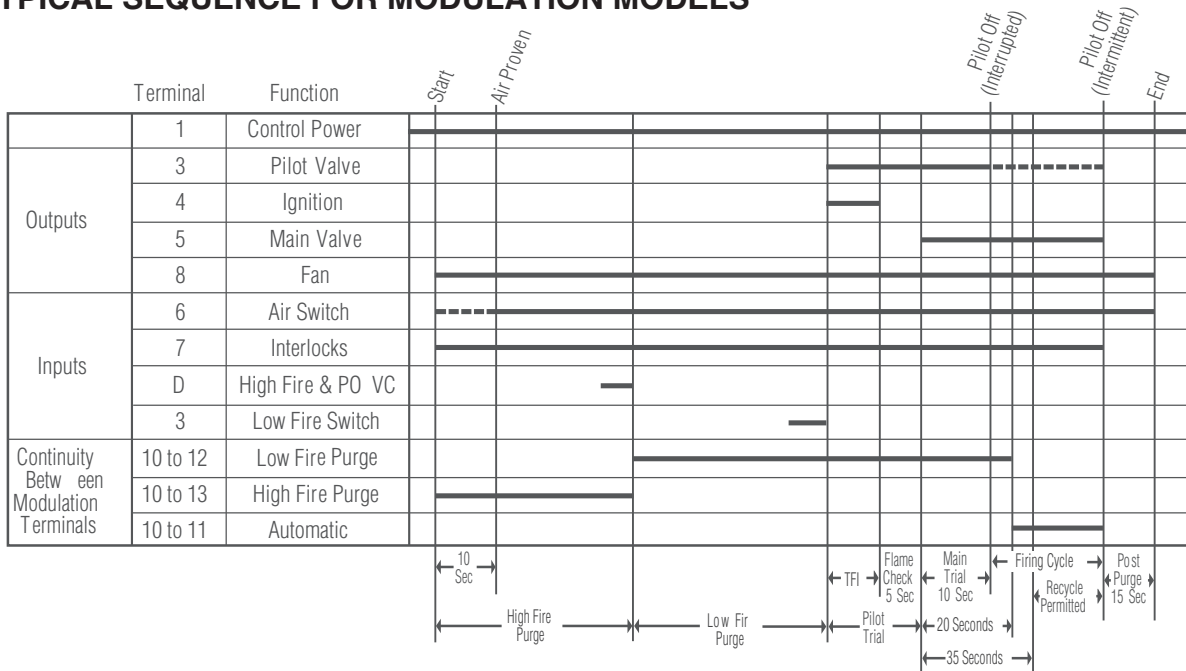

SENSOR INSTALLATION



WARNING: Incorrect sensor installation may cause the sensor to generate a false flame signal, causing unburned fuel to collect in the combustion chamber. The result can be explosions, injuries and property damage. Be certain that the flame sensor detects only pilot and main flames, not glowing refractory, burner or ignition parts.

SENSOR WIRING

Route sensor wiring a sufficient distance from ignition and other high voltage wiring to avoid electrical interference. Wherever possible, try to terminate the flexible metal shield surrounding the leads within inches of the Multi-Burner Control terminals. If the shield must be grounded to reduce interference, ground the shield at the control end to the shield terminal. For self-checking UV scanners, ground both braided shields. To achieve the maximum wiring distance, the shield should not be grounded (keep in mind that an ungrounded shield provides less protection against electrical interference).

Do not ground the shield to terminal GND.

Note: Unshielded sensor wiring must not be run in common with other wires; it must be run in separate conduit. Multiple flame sensor wiring must not be run together in a common conduit or wireway. Use #14 to #18 AWG wire suitable for 90°C (194°F) and 600 volt insulation, and run each pair of leads in its own shielded cable. Multiple shielded cables can be run in a common conduit.

* The burner at which a flame fails will be identified by a flashing red “FLAME FAIL” LED on the corresponding flame sensing module.

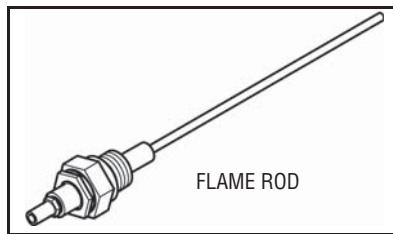

FLAME RODS

Flame rods should be used only on gas burners. They accumulate soot on oil burners, causing nuisance shutdowns and unsafe operating conditions. See the burner manufacturer’s literature for flame rod mounting location. When installing flame rods, please consider the following:

1. Keep the flame rod as short as possible and at least 1/2" (13mm) away from any refractory.
2. Position the rod into the side of both the pilot and main flames, preferably at a descending angle to minimize drooping of the flame rod against burner parts, as shown at left. Flame rod position must adequately detect the pilot flame at all burner draft conditions. Extend the rod 1/2" (13mm) into nonluminous flames, such as blue flames from burning an air/gas mixture. For partially luminous flames, such as atmospheric air/gas mixtures, place the rod at the edge of the flame.
3. Provide a burner/flame grounding area that is at least four times greater than the flame rod area contacting the flame. The flame rod/burner ground ratio and position of the rod in the flame may need adjustment to yield maximum flame signal strength.
4. Ignition interference from the spark plug may increase or decrease the flame signal strength. Reversing the ignition transformer primary leads may reverse this effect. Reducing the spark gap or adding grounding area between the flame rod and spark plug may eliminate the interference.

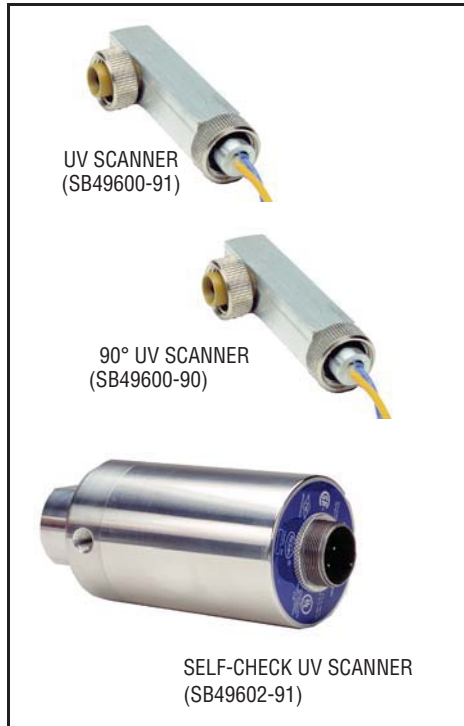

SCANNERS

Use only Fireeye scanner SB49600-91, SB49600-90, SB20898 (not shown) & SB49602-91. Consult the burner manufacturer's instructions for mounting location. When installing scanners, please consider the following:

1. Position the scanner within 18" (457mm) of the flame.
2. Bushing threads are 1/2" F.N.P.T. for scanner models SB49600-91 and SB49600-90; model SB49602-91 has 1" F.N.P.T. bushing threads.
3. The ambient temperature limits of each scanner varies; check the literature supplied with the scanner. For higher temperatures, use Fireeye heat insulator P/N 35-319. If necessary, also use a purge tee.
4. An optional magnifying lens (Fireeye P/N 46-185) may also be used to increase the flame signal strength in difficult sighting situations.

NOTICE

When Fireeye products are combined with equipment manufactured by others and/or integrated into systems designed or manufactured by others, the Fireeye warranty, as stated in its General Terms and Conditions of Sale, pertains only to the Fireeye products and not to any other equipment or to the combined system or its overall performance.

WARRANTIES

FIREYE guarantees for *one year from the date of installation or 18 months from date of manufacture* of its products to replace, or, at its option, to repair any product or part thereof (except lamps, electronic tubes and photocells) which is found defective in material or workmanship or which otherwise fails to conform to the description of the product on the face of its sales order. **THE FOREGOING IS IN LIEU OF ALL OTHER WARRANTIES AND FIREYE MAKES NO WARRANTY OF MERCHANTABILITY OR ANY OTHER WARRANTY, EXPRESS OR IMPLIED.** Except as specifically stated in these general terms and conditions of sale, remedies with respect to any product or part number manufactured or sold by Fireeye shall be limited exclusively to the right to replacement or repair as above provided. In no event shall Fireeye be liable for consequential or special damages of any nature that may arise in connection with such product or part.



FIREYE
3 Manchester Road
Derry, New Hampshire 03038 USA
www.fireeye.com

SB-2501
March 7, 2019

Supersedes Sept. 9, 2018